

Project FESnet

FESnet (Federal Education and Scientific net) is a project of establishing the communication infrastructure of the Czechoslovak academic and scientific community. Its services should be accessible to all those concerned with a scientific and technological cooperation.

Currently, the international information networks are accessible for the limited number of users. The accessibility of these networks for a maximum number of users remains a fundamental problem which cannot be solved on the level of individual republics. This unsatisfactory state should be solved consistently by setting up a suitable distributed infrastructure which can access the international networks. In addition, the proposed infrastructure should create a background of an internal information system and should support an integration of the Czechoslovak academic and scientific community with the outside world.

FESnet is a joined project of the Czech and Slovak academic networking community and INRIA, France. It is open to other parties who intend to support R and D networking in ČSFR.

Basic prerequisites

The connections to international computer networks are accomplished in ČSFR through two most significant European computer nets, i.e. the EUnet and EARN.

The EUnet network is operated by the European association of users of the UNIX operating system (EurOpen) and the corresponding national groups (in ČSFR CSUUG). The Czechoslovak EUnet national node is operated by the Faculty of Mathematics and Physics at the Comenius' University in Bratislava (uniba). In ČSFR this net came into being at the beginning 1990. At present, 16 nodes are operating at the institutions of higher

education, the private software firms and institutions of state administration in Prague, Bratislava, at Liberec and Košice as well, with total number of about 500 users. All communication in this net is implemented in ČSFR exclusively through switched lines (including the international connection to the Amsterdam mcsun node).

The electronic mail is the only service provided by means of this net; the present hardware does not make the conferencing service possible. The EUnet provides the E-mail and the only the EARN network (Academic and Research net) is the network of European academic workplaces and non-commercial research institutes. Its national node is the Czech Technical University in Prague.

The net in ČSFR has been operated since October 1990 and at present it consists of 7 nodes (4 at the institutions of higher education, 3 in Czechoslovak Academy of Sciences); all of them are located in Prague. The total number of registered users exceeds 1400. The interconnection of the individual nodes are interconnected by means of leased telephone lines; as a rule, in individual nodes the access of users even through switched lines is possible. In addition to the electronic mail this net offers conferencing services and file transfer. The IBM computers and IBM similar mainframe (RJAD) represent the typical hardware of this net in ČSFR.

The present and future development of both above mentioned nets obviously aims at using the set of protocols the TCP/IP of industry standard TCP/IP. These protocols are used by the INTERNET world-wide scientific and academic net (about 350.000 nodal computers in the whole world). The access to this net does not depend on using technical facilities of a specific producer. The possibility of interactive access to the net resources is the marked qualitative difference compared with above-mentioned nets.

By the end of October 1991, Czechoslovak EARN and EUnet national nodes in Prague and Bratislava should be connected to the INTERNET. The distribution of the access to these nodes and their mutual communication is not ensured for the time being and present technical state does not render it possible: The federal communication infrastructure (FESnet) for the academic and scientific community should solve this problem.

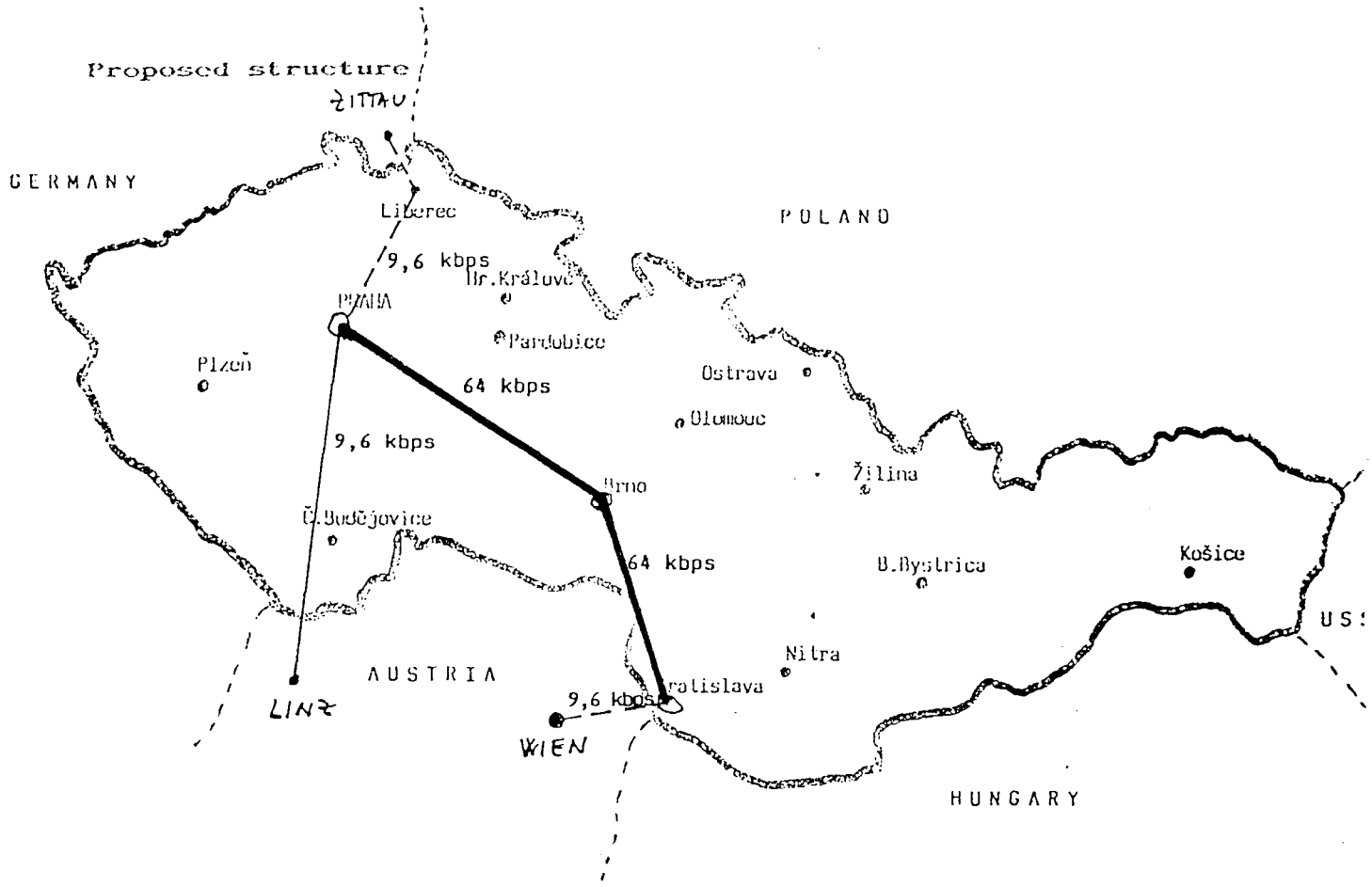
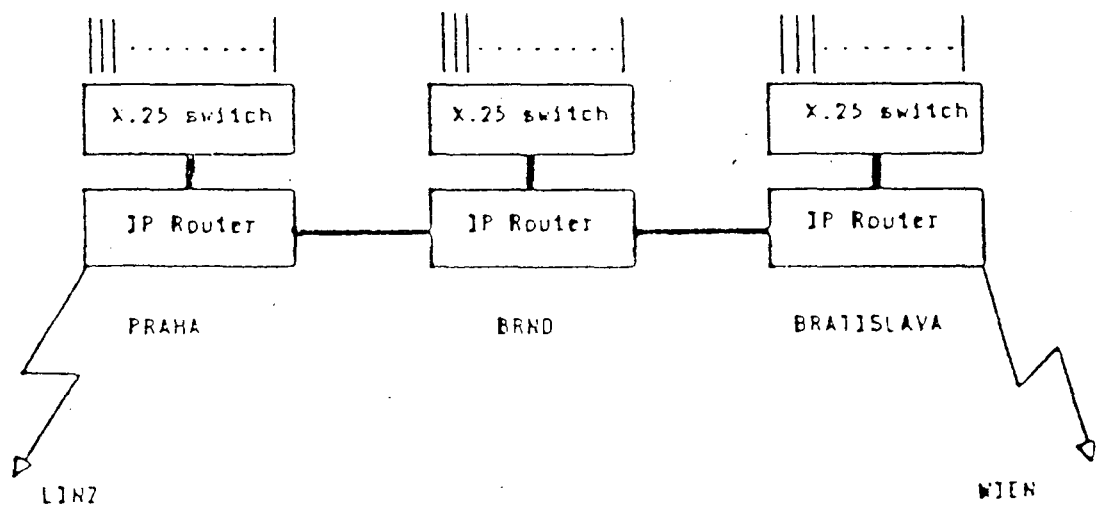

fig. 1

The medium speed (64 Kbit/s) leased circuits interconnected with IP routers form the backbone of the network. Both the current (Linz, Wien) and any future international connections, should be connected in nodal points. The access to nodal points will be carried out by means of X.25 switches.

The interconnection of the FESnet nodes is shown in fig. 2:



All proposed variants should integrate a suitable corresponding full-duplex sync. modem and integration of these facilities into a local infrastructure at individual users. This project is not concerned with forming of local infrastructures of individual users and assumes the maximum utilization of existing facilities or arising ones created and financed from other resources. Giving consultations by a group of experts coordinating the integration of individual localities into the proposed infrastructure is the part of the project. Even at present it is possible to mark out several localities of users who have or will have the local infrastructure prepared for this integration (ČVUT, VŠE). In a number of other cases the project FESnet gives the decisive impulse to the follow-up activities in individual localities. In all three main nodes of FESnet there is a sufficient reserve for integration of significant localities of higher education, science and research within a region concerned, either by means of leased lines or services of the emerging EUROTEL packed public network.

Proposed procedure of implementation

I. stage (by the end of 1991)

The creating of basic multiprotocol backbone net of FESnet including the integration of international coupling (see fig. 1 and 2) and connection of existing local nets which are or soon will be ready for this integration.

II. stage (after 1991)

The connection of further localities and cities (Liberec, Plzeň, České Budějovice, Hradec Králové, Pardubice, Ostrava, Olomouc, Žilina, Nitra, Banská Bystrica, Košice) in a way as they will be prepared for this activity. The support of new users provided by the selected nodes or with the help of less effective telecommunication channels (e.g. switched lined), which eliminates a certain information vacuum and assistance to adaptation for net services.

Each of three main nodes will be equipped with

- 1) switch X.25 with 16 serial parts
- 2) IP router with 4 serial parts and 2 elements for local net Ethernet
- 3) technical facilities for the implementation of data circuits 64 Kbit/s
- 4) modem for data circuits of access to X.25 switch.

The connection of local nets of user organizations and existing EARN nodes will be carried out in dependence on local hardware and on conditions of some of the following variants:

- a) PC-router, personal computer in corresponding configuration including the adapters X.25 and Ethernet including the appropriate software

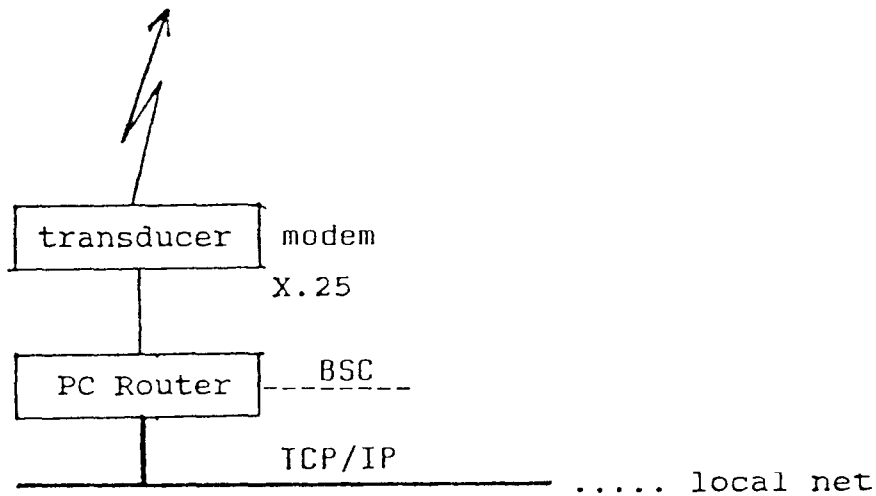

fig. 3

b) the computer operates under the operating system UNIX equipped with adapter X.25 or with the adapter Ethernet for connection to local net too.

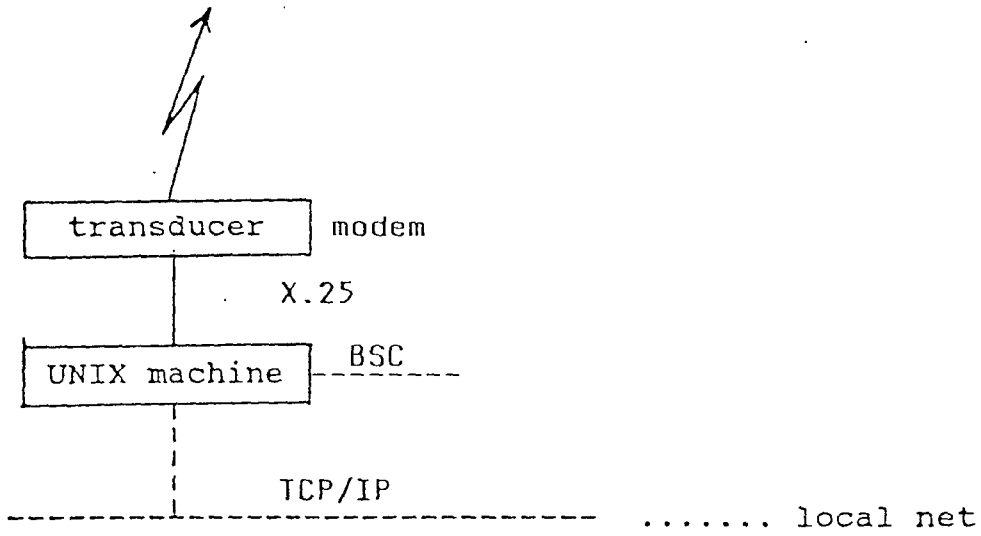

fig. 4

c) dedicated IP router with appropriate adapters X.25 and Ethernet

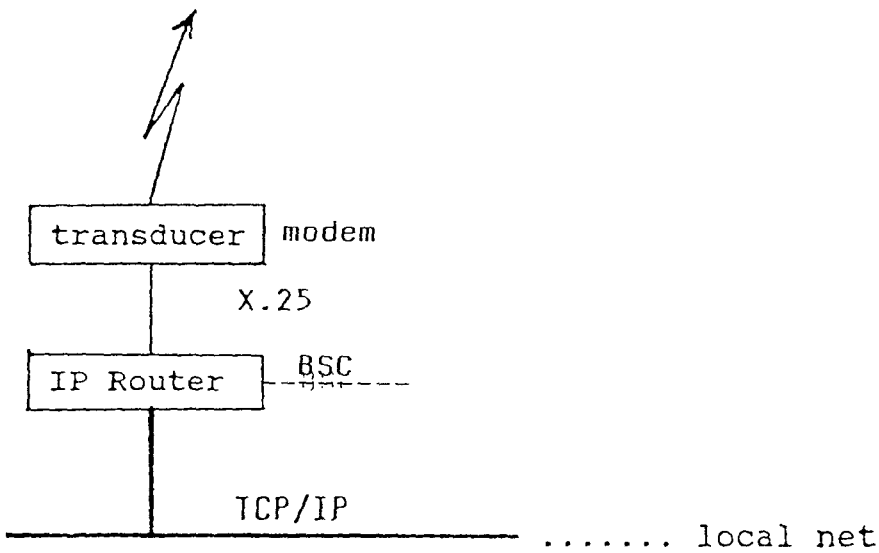

fig. 5

Where required the router will include the BSC port for the connection of the EARN nodes.

What to do now:

- 1) In order to realize I. stage of the project it is necessary to raise funds for the leased lines Praha-Brno and Brno-Bratislava.
- 2) Select the sites in Praha, Brno and Bratislava where IP routers and X.25 switches will be installed.
- 3) Order leased lines.
- 4) Select the people who will operate the backbone and organize the training.
- 5) With cooperation with operate the backbone and organize the training.
- 6) Start negotiate with the INRIA about the delivery of the equipment (some used SUN workstations would be very appreciated).
- 7) Organize an international seminar in Prague about the academic networking in ČSFR in November 1991.

Prague, July 31th 1991

FESnet coordination team:

BOBOVSKÝ Jaroslav (bobovsky@csearn.bitnet) - SVT SAV Bratislava
BUECHLER Gejza (gejza@mff.uniba.cs) - UK Bratislava
DEVILLERS Yves (yves.devillers@inria.fr) - INRIA, Francie
GRUNTORÁD Jan (tkjg@csearn.bitnet) - ČVUT Praha
ORSÁG Jiří (orse@vscht.cs) - VŠCHT Praha
SVOBODA Zdeněk (zsvoboda@csearn.bitnet) - ÚIV Praha
TROJAN Václav (trojan@csearn.bitnet) - UK Praha
ŠMEJKAL Ivo (ivo@vse.cs) - VŠE Praha
ŠTĚRBA Milan (sterba@corton.inria.fr) - INRIA, Francie